

AUTOMATIC WEIGHT TESTER FOR BOXES

40CPL1-I

OPERATION

This equipment is appropriate to be installed in filling lines at the outlet of the carton or boxing equipment.

It is capable of verifying the correct content in the closed boxes discovering the rarity of product within or the missing of any bottle.

This automatic testing equipment possesses a microprocessor which allows a large versatility on changes in production levels and modifications of weighing parameters (capacity, division, etc).

CHARACTERISTICS

- Inlet motorised conveyor and electronic speed variator for separating boxes.
- Conveyor for bottle weighing, motorised and with electronic speed variator.
- Outlet conveyor with motorised rollers and electronic speed variator.
- Supporting structure with height adjustable legs for different kinds of bottles.
- Refusal unit with free rollers lateral conveyor.
- Refusal timing and performance programmable time.
- Weight value programming (minimum acceptable level).
- Weight tolerance programming, only available with automatic value.
- Data displayed on a LDC luminiscent display.
- Warning on case of lacking weight box.
- Internal counters for boxes with right weight (acceptable) and lacking weight (inacceptable).
- Automatic calibration of zero and gain.

SPECIFICATIONS

- **Electrical supply:** 220 Vac , 50/60 Hz. + earth connection
- **Installed Power:** 350 Watts.
- **Pneumatic supply:** Filtered air 3 and 8 Kg/cm².
- **Weight:** 100 Kg.
- **Production:** upto 20 boxess/minute.

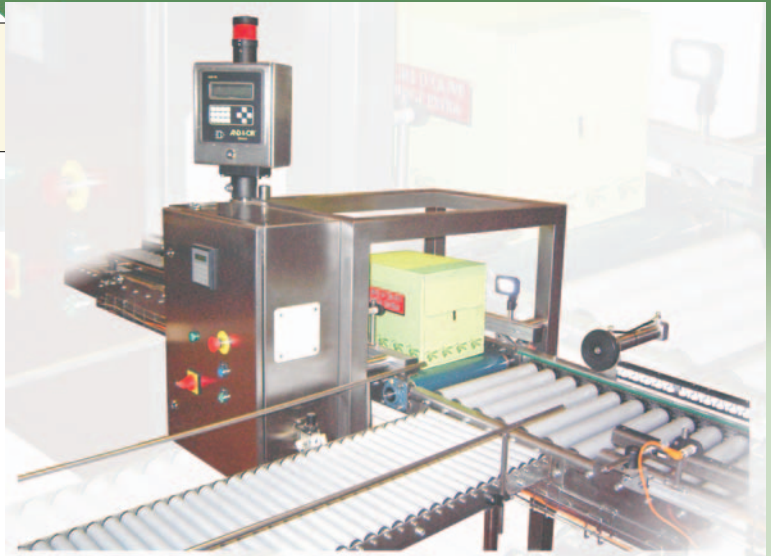

LAY-OUT

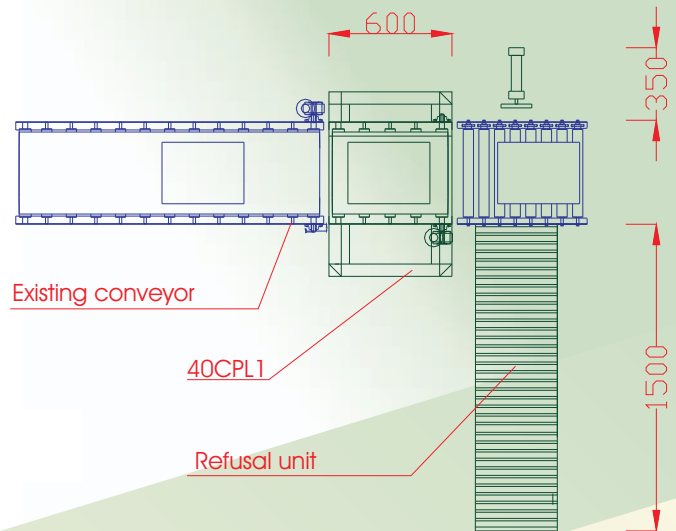

OTHER EQUIPMENTS

- **Leakage and weight testers.**
- **Automatic packaging machine with thermosealing.**
- **Arranging desk and palletising robots.**
- **Bottles conveyors.**
- **Handle insertion equipments.**
- **Robots for extracting and placing bottles on boxes.**



Blas Infante Av. s/n. - La Ladrillera Industrial Zone - Odiel St., nº 3, 5, 7 y 9.
41100 CORIADEL RIO (Seville) - Post Office Box, 31
Telephone: 34 - 95 - 477 33 02 / 92 00 - Fax: 34 - 95 - 477 42 44

E-mail: andyor@andyor.com
<http://www.andyor.com>