

ROTARY SYSTEM FOR APPLICATING HANDLES

50SIA10000LSR

DEFINITION

Our system **50SIA10000LSR** carries out the insertion of handles (PE) on PET bottles from 1,5 to 3 litres. It is based in a rotary equipment with continuous movement and it is most appropriate to be installed on the existing conveyor and after the capping or labelling process.

Production: up to 9.000 u/h.

For further productions the following models are available: 50SIA24000LSR (up to 24.000 u/h), 50SIA15000LSR (up to 16.000 u/h), 50SIA5000R&P2-TL (up to 5.500 u/h), 50SIA3000R&P2-TL (up to 3.500 u/h), 50SIA2000LSA2-2 (up to 2.400 u/h) or 50SIA1000LSA1-1 (up to 1.200 u/h).

CHARACTERISTICS

- Insertion Unit:

- Bottle supply by plastic hinge conveyor, lateral conveyor (for pressure relief) worm gear and inlet/outlet star.
- Kit of 8 headstocks positioned over central star.
- Positioning of insertion headstocks by central star.
- Automatic synchronization with bottling line.
- Speed controlled by electronic regulator with start/stop ramp.
- Refusal units for bottles without handles and free roller conveyor.
- Control board (built in stainless steel) based on a PLC with keyboard touch display for parameters modification, data displaying (production), indicating reasons of stops (lack of bottles, handles, etc...). Warning lights to indicate the state of line at distance.
- Built in stainless steel with protective gates in PET, shock resistant and with safety elements according to European norms.

- Handle supply unit:

- Reception hoppers and handle supply to vibrator.
- Vibration unit to position handles.
- Handle conveyor to insertion unit with turning over device and handle orientation with artificial vision system.

SPECIFICACIONES

- **Operation Voltage:** 220 Vac, 50/60 Hz.
- **Installed power:** 4 Kw..
- **Air consumption.-** 1.000 NL/minute.
- **Pneumatic supply:** Filtered Air (6-8 Kg/cm²).
- **Dimensions:** Vid. La-out.
- **Weight:** 2.500 Kg.



LAY-OUT

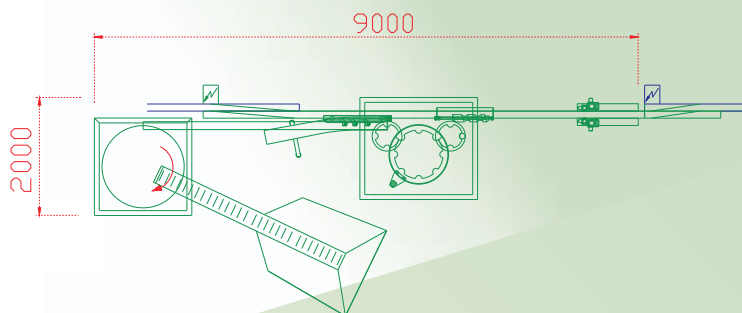

OTHER EQUIPMENTS

- Lineal, rotary etc leakage testers.
- Automatic packagers with thermosealing.
- Palletisers/depalletisers for empty bottles.
- Special bottle conveyors.
- End solutions for bottling lines.
- Weight-in-a-box testers.



AND & OR® S.A.



Blas Infante Av. s/n. - La Ladrillera Industrial Area - Odie St. I,nº 3, 5, 7 & 9.
41100 CORIADEL RIO (Seville) - Post Office Box, 31
Telephone: 34 - 95 - 477 33 02 / 92 00 - Fax: 34 - 95 - 477 42 44

E-mail: andyor@andyor.com
<http://www.andyor.com>