

AUTOMATIC SYSTEM FOR INSERTING HANDLES

50SIA1000LSA1-1T

DEFINITION

Our system **50SIA1000LSA1-1T** carries out the insertion of polyethylene handles (PE) on PET full bottles of 1, 5 and 8 litres. It is based in a machine with alternative movement and it is most appropriate to be installed on the bottling line (full bottles) on the existing conveyor and after the capping or labelling process. It prevents the problems which may occur in deposits, positioning or filling equipments etc... with bottles with incorporated handles, it produces as well an important economy since it is unnecessary to purchase bottles with handles.

Maximum output = 1.200 bottles/hour

For a higher output the following models are available: 50SIA2000LSA2-2T (up to 2.400 u/h), 50SIA3000R&P2-TL (up to 3.500 u/h), 50SIA5000R&P2-TL (up to 5.500 u/h) and 50SIA98000R&P3-TL (up to 8.000 u/h).

CHARACTERISTICS

- Insertion unit:

- Bottle supply by a conveyor belt.
- Transversal carriage with handle collect and inserting headstock synchronised to mask for holding bottles with mechano-pneumatic driving system.
- Refusal unit for bottle without handle.
- Control board (built in stainless steel) based on a PLC with keyboard touch display for parameters modification, data displaying (production), indicating reasons of stops (lack of bottles, handles, etc...). Warning lights to indicate the state of line at distance.
- Built in painted steel with protective gates in PET, shock resistant and with safety elements according to norms.

- Handle supply unit:

- Reception hopper and handle supply to vibrator.
- Platform support with positioning vibrator for handles.
- Orientator with artificial vision system and handle conveyor to insertion unit with double cavity plate and pneumatic displacement.

TECHNICAL SPECIFICATIONS

- **Electric supply:** 220 Vac, 50/60 Hz.
- **Installed power:** 1,5 Kw.
- **Pneumatic supply:** Filtered air 6-8 Kg/cm².
- **Air consumption:** 800 NI/min
- **Dimensions:** vid. Layout.
- **Weight:** 1.025 Kg.



LAY-OUT

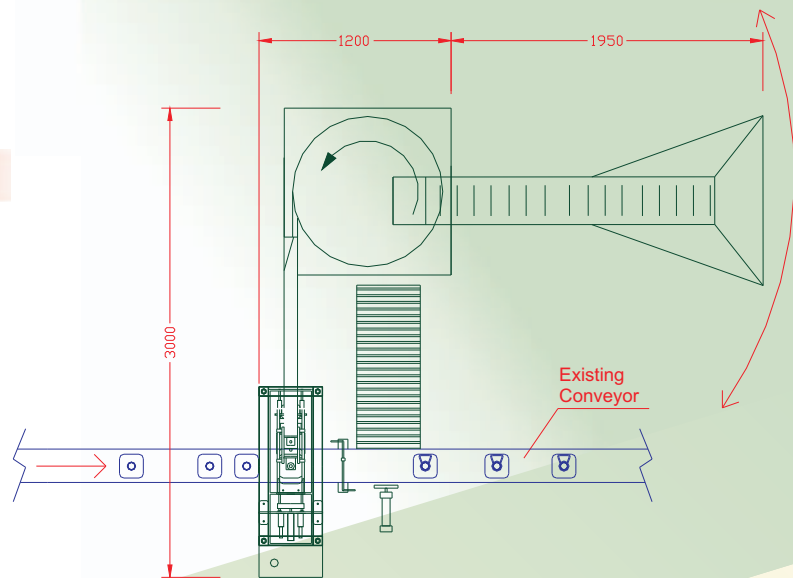

OTHERS EQUIPMENTS

- Lineal, rotary etc leakage testers.
- Automatic packagers with thermosealing.
- Palletisers/depalletisers for empty bottles.
- Special bottle conveyors.
- End solutions for bottling lines.
- Weight-in-a-box testers.



AND & OR® S.A.



Blas Infante Avenue-"La Ladrillera" Industrial Area
Odiel Street, 3, 5, 7 and 9. - 41100 CORIA DEL RÍO (Seville) - P.O. Box 31
Telephone: 34 - 95 - 477 92 00 / 33 02 - Fax: 34 - 95 - 477 42 44

E-mail: andyor@andyor.com
<http://www.andyor.com>