

# AUTOMATIC SYSTEM FOR INSERTING HANDLES

## 50SIA2000LSA2-2

### DEFINITION

Our system **SIA2000LSA2-2** carries out the insertion of polyethylene handles (PE) on PET empty bottles of 1, 5 and 8 litres. It is based in a machine with alternative movement and it is most appropriate to be installed at the outlet of the blow moulding equipment (PET) (Empty bottles).

**Maximum Production = 2.400 bottles/hour.**

For a higher outputs, the following models are available: 50SIA3000R&P2-TL (up to 3.500 u/h), 50SIA5000R&P2-TL (up to 5.500 u/h) and 50SIA8000R&P3-TL (up to 8.000 u/h).

### CHARACTERISTICS

#### - Insertion unit:

- Bottle supply by a conveyor belt.
- Transversal carriage with handle collect and inserting headstock synchronised to double mask for holding bottles with mechano-pneumatic driving system.
- Refusal unit for bottle without handle.
- Control board (built in stainless steel) based on a PLC v keyboard touch display for parameters modification, displaying (production), indicating reasons of stops (lack bottles, handles, etc...). Warning lights to indicate the stop of line at distance.
- Built in painted steel with protective gates in PET, shock resistant and with safety elements according to norms.

#### - Handle supply unit:

- Reception hopper and handle supply to vibrator.
- Platform support with positioning vibrator for handles.
- Orientator with artificial vision system and handle conveyor to insertion unit with double cavity plate and pneumatic displacement.

### TECHNICAL SPECIFICATIONS

- **Electric supply:** 220 Vac, 50/60 Hz.
- **Installed power:** 1.5 Kw.
- **Pneumatic supply:** Filtered air 6-8 Kg/cm<sup>2</sup>.
- **Air consumption:** 800 NI/min
- **Dimensions:** vid. Lay-out.
- **Weight:** 1.050 Kg.



### LAY-OUT

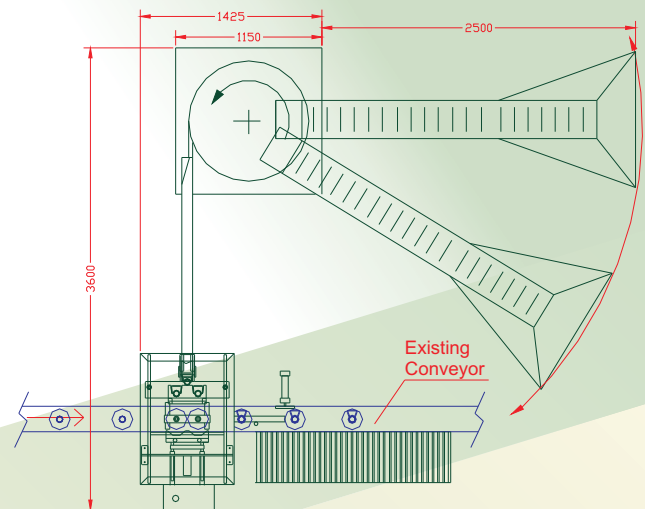

### OTHERS EQUIPMENTS

- Lineal, rotary etc leakage testers.
- Automatic packagers with thermosealing.
- Palletisers/depalletisers for empty bottles.
- Special bottle conveyors.
- End solutions for bottling lines.
- Weight-in-a-box testers.



Blas Infante Avenue-"La Ladrillera" Industrial Area  
Odiel Street, 3, 5, 7 and 9. - 41100 CORIA DEL RÍO (Seville) - P.O. Box 31  
Telephone: 34 - 95 - 477 92 00 / 33 02 - Fax: 34 - 95 - 477 42 44

E-mail: [andyor@andyor.com](mailto:andyor@andyor.com)  
<http://www.andyor.com>