

LINEAL SYSTEM FOR HANDLE APPLICATION

50SIA3000R&P2-TL

DEFINITION

Our system **SIA3000R&P2-TL** carries out the insertion of handles (PE) on PET bottles of 1, 5 and 8 litres. It is based in a lineal machine with continuous movement and it is most appropriate to be installed in the bottling line, on the existing conveyor and after the capping or labelling process. It prevents the problems which may occur in deposits, positioning or filling equipments etc... with bottles with incorporated handles, it produces as well an important economy since it is unnecessary to purchase bottles with handles.

Production: 3.500 u/h ÷ 4.500 u/h.

For further productions the following models are available : SIA5000R&P2-TL (up to 5.500 u/h), SIA8000R&P2-TL (up to 8.000 u/h), SIA2000LSA2-2 (up to 2.400 u/h) or SIA1000LSA1-1 (up to 1.200 u/h).

CHARACTERISTICS

- Insertion Unit:

- Bottle supply to insertion area by existing conveyor belt.
- Lateral double width-adjustable conveyor (50÷300mm) for pressure relief and sequence of bottles.
- Handle insertion by adjustable lineal system.
- Fitting to bottle height by flying steers.
- Refusal units for bottles without handles and free roller conveyor.
- Control board (built in stainless steel) based on a PLC with keyboard touch display for parameters modification, data displaying (production), indicating reasons of stops (lack of bottles, handles, etc...). Warning lights to indicate the state of line at distance.
- Built in stainless steel with protective gates in PET, shock resistant and with safety elements according to norms.

- Handle supply unit:

- Reception hopper and handle supply to vibrator.
- Platform with vibration unit to position handles.
- Handle conveyor to insertion unit with turning over device and handle orientation with artificial vision system.

TECHNICAL SPECIFICATIONS

- **Electrical supply:** 220 Vac, 50/60 Hz.
- **Installed power:** 2 Kw.
- **Pneumatic supply:** Filtered Air (6-8 Kg/cm²).
- **Air consumption:** 800 NI/minute.



- **Dimensions:** vid. Lay-out.
- **Weight:** 1.255 Kg.

LAY-OUT

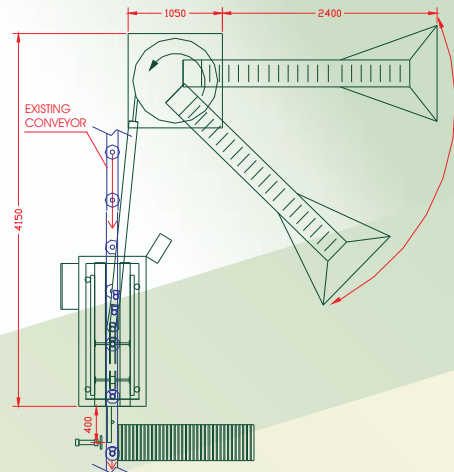

OTHERS EQUIPMENTS

- Lineal, rotary etc leakage testers.
- Automatic packagers with thermosealing.
- Palletisers/depalletisers for empty bottles.
- Special bottle conveyors.
- End solutions for bottling lines.
- Weight-in-a-box testers.



AND & OR® S.A.



Blas Infante Avenue-"La Ladrillera" Industrial Area
Odiel Street, 3, 5, 7 and 9. - 41100 CORIA DEL RÍO (Seville) - P.O. Box 31
Telephone: 34 - 95 - 477 92 00 / 33 02 - Fax: 34 - 95 - 477 42 44

E-mail: andyor@andyor.com
<http://www.andyor.com>