

PACKAGING SYSTEM FOR EMPTY BOTTLES ON TRAY / BAG

60EMA1400BC-PR

OPERATION

This **AND & OR 60EMA1400BC-PR** system carries out the arranging and automatic insertion of bottles either on a carton tray or into a bag which is completely closed by a thermosealing system.

It is usually installed at the outlet of the blow moulding equipment after the leakage test.

It offers a packaging and/or bagging system for bottles automatically arranged, the participation of a worker is only necessary to change the tray or bag according to the selected system which allows him to work on several equipments at a time.

CHARACTERISTICS

The whole system consists of several items clearly different:

- Existing bottle conveyor.
- Arranging and packaging desk 60EMA1400BC-PR, with the following main characteristics:
 - Painted metallic structure with height-adjustable legs and brake wheels.
 - Upper metallic covers (dust protection) and protective barrier on sealing area.
 - Bottle pusher with automatic indexer.
 - Arranging and manipulating desk with holding carriage and bag tense.
 - Thermosealing unit for closing bag.
 - Metallic interchangeable tray (carton tray format 800x1200 or 1000x1200) with internal width-adjustable guides.
 - Metallic interchangeable tray for bag (800x1200)
 - Motorised mobile tray with electronic speed variator, support base for conveying carton tray or bag.
 - Unit controlled by an OMRON CPL and keyboard/display for alarm data programming and displaying.
 - External warning lights for equipment state and alarms.

SPECIFICATIONS

- **Electric supply:** 220 Vac. 50/60 Hz.
- **Installed power:** 1 Kw.
- **Pneumatic supply:** from 6 upto 8 bar.
- **Dimensions:** according to lay-out.
- **Approximate weight:** 375 Kgs



LAY-OUT

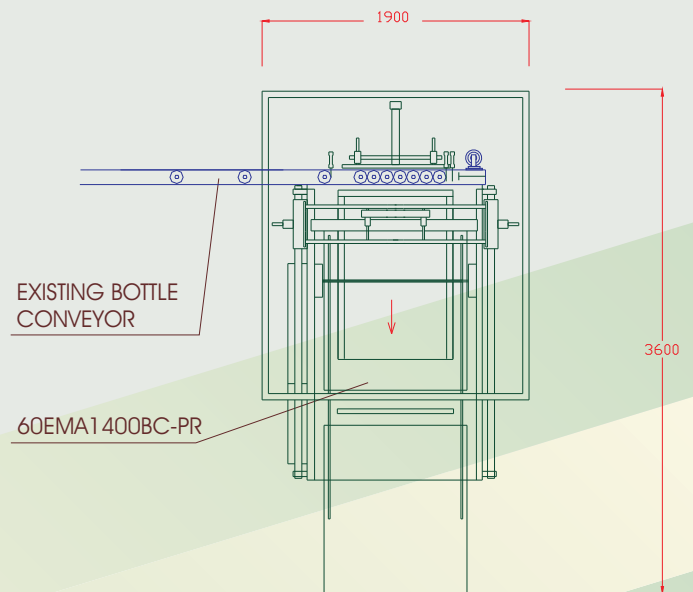

OTHER EQUIPMENTS

- Robots and bottle manipulators.
- Leakage testers.
- Weight-in-a-box testers.
- Automatic bagging system with thermosealing.
- Handle applicator equipments.
- Bottle conveyors.



AND & OR® S.A.



Blas Infante Av. s/n. - La Ladrillera Industrial Area - Odiel St. n° 3, 5, 7 & 9.
41100 CORIA DEL RIO (Seville) - P. O. Box, 31
Telephone no: 34 - 95 - 477 33 02 / 92 00 - Fax: 34 - 95 - 477 42 44

E-mail: andyor@andyor.com
<http://www.andyor.com>