

# AUTOMATIC ARRANGING AND PALLETISING SYSTEM FOR BOTTLES

**60EMAM1400-DV+ 60RPZ3000G270-MP+  
+ 10SCARTON6-8**

## DEFINITION

This **AND&OR** equipment carries out the arranging and automatic insertion of bottles onto a carton tray and then palletises them.

This system includes the automatic palletising as well as the supply of sheets or carton trays, in order to separate the different levels of the pallet. In addition, the automatic supply of pallet is possible.

## CHARACTERISTICS

These systems are usually composed of these parts:

- Automatic desk for format preparation for sheet or carton tray Mod. **60EMAM1400-DV** which includes:
  - Inlet pince/pusher for bottles with pneumatic driving system.
  - Automatic indexing system X-X or X-Y.
  - Conveying belt for bottles with displacement control for format formation.
  - Central control unit including: OMRON PLC, touch display for data programming and displaying as well as kind of warnings, set of speed inverters.
- Tray palletising robots Mod. **60RPZ300G270-MP** with following main characteristics:
  - Carriage with vertical displacement and motorised rotation.
  - Jib with frame for holding bottles and collecting trays.
  - Electronic control unit with OMRON PLC, display-keyboard for data programming and displaying.
- Motorised accumulative support for empty cartons Mod. **60SCARTON6.8** (CAPACITY 8 units).

## SPECIFICATIONS

- **Electrical supply:** 220 Vac. 50/60 Hz.
- **Installed power:** from 2 upto 3 Kw.
- **Pneumatic supply:** from 6 upto 8 bar.
- **Standard system** for Euro-trays 800x1200 or 1000x1200. (Further sizes on demand).
- **Dimensions:** according to lay-out.

## OTHER EQUIPMENTS

- **Robots and bottle handlers.**
- **Leakage and weight testers.**
- **Weight-in-a-box testers.**
- **Automatic bagging systems.**
- **Handle insertion equipments for bottles.**
- **Bottle conveyors.**



## LAY-OUT

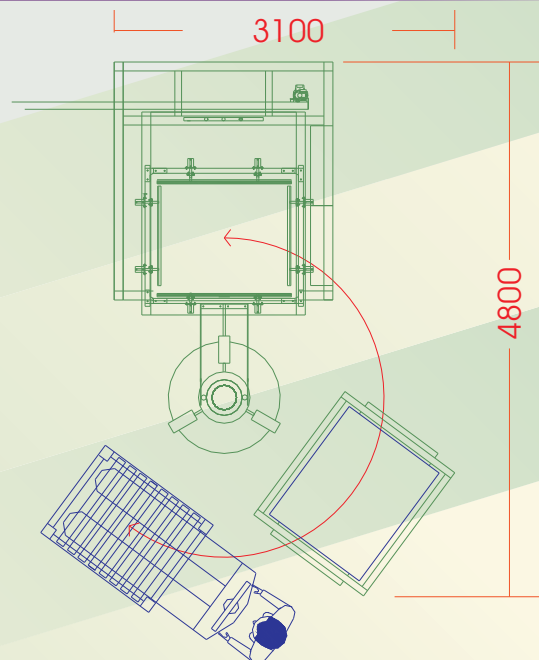

Specifications may change without any prior notice. Ref.03.08-IN

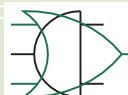

**AND & OR**®

S.A.



Blas Infante Avenue - La Ladrillera Industrial Area - Odiel St. nº 3, 5, 7 & 9.  
41100 CORIADEL RIO (Seville) - P. O. Box nº 31  
Telephone: 34 - 95 - 477 33 02 / 92 00 - Fax: 34 - 95 - 477 42 44

E-mail: [andyor@andyor.com](mailto:andyor@andyor.com)  
<http://www.andyor.com>