

BOTTLE RECEPTION SYSTEM

60REC600 + 10TAC1500-P

OPERATION

The **60REC600-4** + the **10TAC1500-P** is a proficient and completely automatic system to collect turned-over bottles at the outlet of the blow moulding machine such as NISSEI, UROLA, MAGPLASTIC etc., and placing them on a conveyor belt located at a different height. For a rotary blow moulding machine such as the SIDEL with an orderly outlet, the **10TAC1500-P** is installed directly without the **60REC6**.

Because of this collecting system any mark or damages by rubbing which occur in systems where the outlet is by a ramp where the bottles must be collected after they have fallen down.



CHARACTERISTICS

This height-adjustable bottle extraction machine **60REC600** is equipped with the following characteristics:

- Bottle reception platform with suction base.
- Conveyor adaptation to bottle height by mechanic driving system. Maximum stroke 200 mm.
- Supporting base with joining leg to blow moulding machine.
- Electro-pneumatic unit controlled by a mini-robot OMRON CPM1-10. (Synchronised with turn-over device of blow moulding machine).

The height-adjustable bottle conveyor **10TAC1500-P** with adjustable slope for height adjustment is equipped with the following main characteristics:

- Chassis in aluminium profiles. Length 1.500 mm.
- Bottle transport by bottle neck ring with motorised polycord cord.
- Lateral adjustable guides in stainless steel.
- Motor-reducer with electronic speed inverter.
- Automatic refusal unit for bottles (internal) by bottle accumulation at the outlet.

SPECIFICATIONS

- Electrical supply: 220 Vac. 50/60 Hz.
- Installed power: 0.24 CV.
- Pneumatic supply: from 6 up to 8 bar.
- Dimensions: according to lay-out.

LAY-OUT

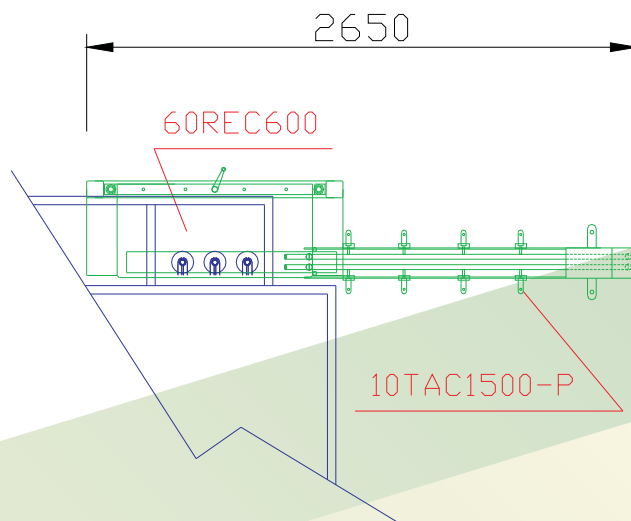

OTHER EQUIPMENTS

- Bottle arranging and packaging desk.
- Bottle palletising robots.
- Robots and handlers for bottles.
- Leakage testers.
- Weight-in-a-box controllers.
- Automatic packaging machines with thermo-sealing.
- Handle applicator machines on the neck of bottles.



AND & OR® S.A.



Blas Infante Avenue-"La Ladrillera" Industrial Area
Odriel Street, 3, 5, 7 and 9. - 41100 CORIADEL RÍO (Seville) - P.O. Box 31
Telephone: 34 - 95 - 477 33 02 / 92 00 - Fax: 34 - 95 - 477 42 44

E-mail: andyor@andyor.com
<http://www.andyor.com>